

PUR13

- Ⓓ MONTAGEANLEITUNG : DREHTÜR 1-TLG.+ SEITENWAND IN FLUCHT
- Ⓖᵇ INSTALLATION INSTRUCTIONS : HINGED DOOR + IN LINE FIXED PANEL
- Ⓕ NOTICE DE MONTAGE : PORTE PIVOTANTE + PAROI FIXE EN LIGNE
- Ⓒᵗ NÁVOD K MONTÁŽI : OTOČNÉ DVEŘE +BOČNÍ STĚNA V ROVINĚ
- Ⓖᵗ INSTRUKCJA MONTAŻU : DRZWI OBROTOWE + ŚCIANKA BOCZNA W LINIE
- Ⓒᵗ NÁVOD NA MONTÁŽ : JEDNOKRÍDLOVÉ DVERE +PEVNÁ STENA
- Ⓕ SZERELÉSI ÚTMUTATÓ : NYÍLÓAJTÓ 1-RÉSZES + OLDALFAL 180°
- Ⓔ INSTRUCCIONES DE MONTAJE : PUERTA + FIJO EN LÍNEA
- Ⓓᵗ INSTRUCTIUNI DE MONTAJ : UȘĂ PIVOTANTĂ DINTR-O BUCATĂ + PARTE FIXĂ ÎN CONTINUARE



BENÖTIGTES WERKZEUG :

NECESSARY TOOLS :

OUTIL NÉCESSAIRE :

NÁŘADÍ POTŘEBNÉ PRO MONTÁŽ :

SCULE NECESARE :

POTRZEBNE NARZĘDZIA :

POTREBNÉ NÁRADIE:

SZÜKSÉGES SZERSZÁMOK :

HERRAMIENTAS NECESARIAS :



1x

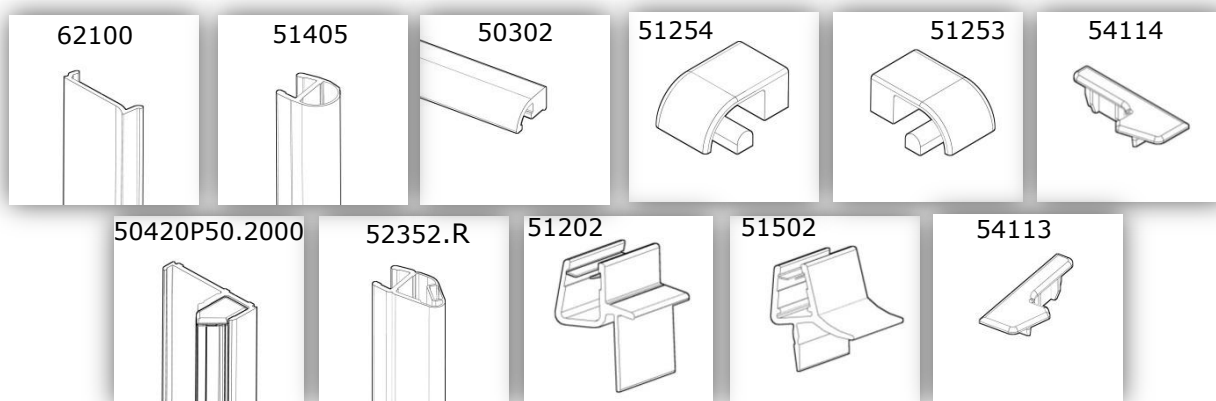
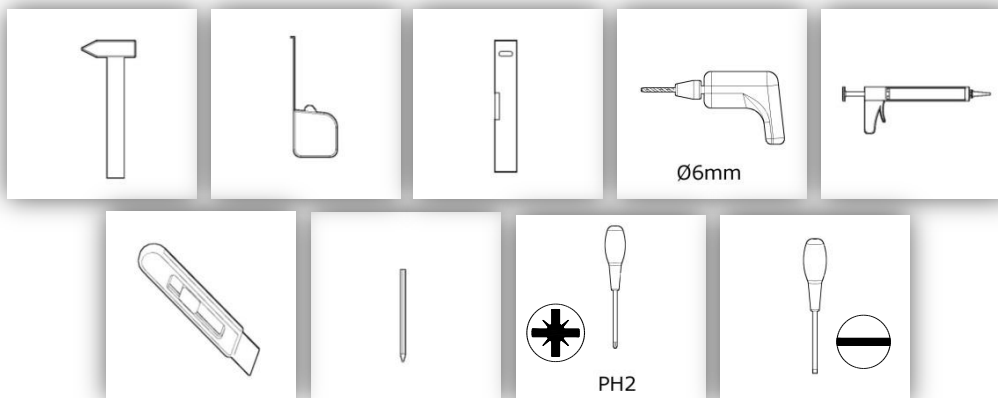

ZUBEHÖR :

EQUIPEMENT :

ACCESSOIRES :

PŘÍSLUŠENSTVÍ :

ACCESORII :

DODATKI :

PRÍSLUŠENSTVO :

ALKATRÉSZEK :

ACCESORIOS:

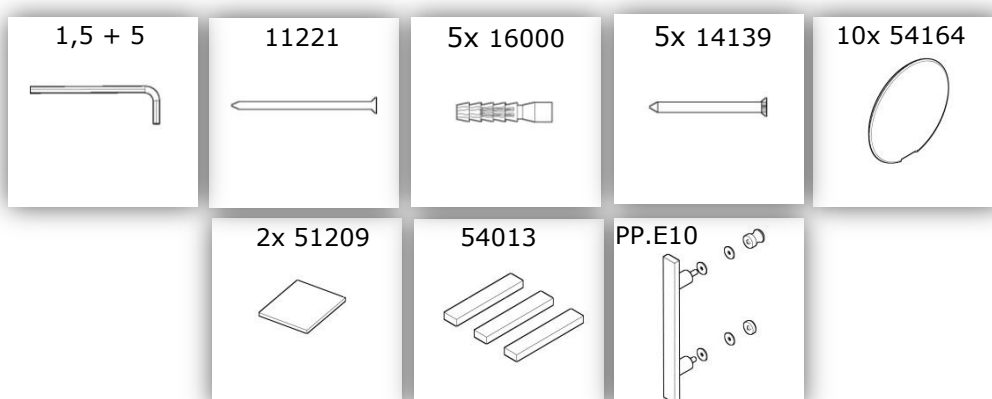

1

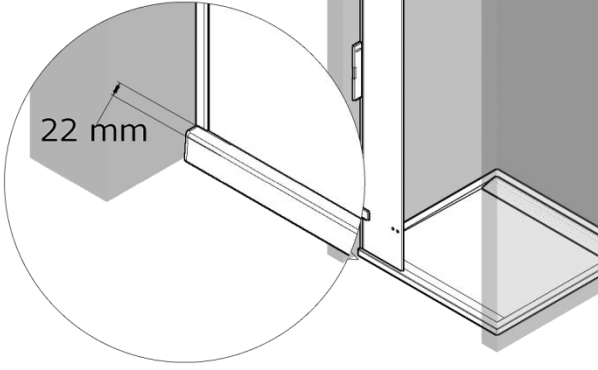

1a

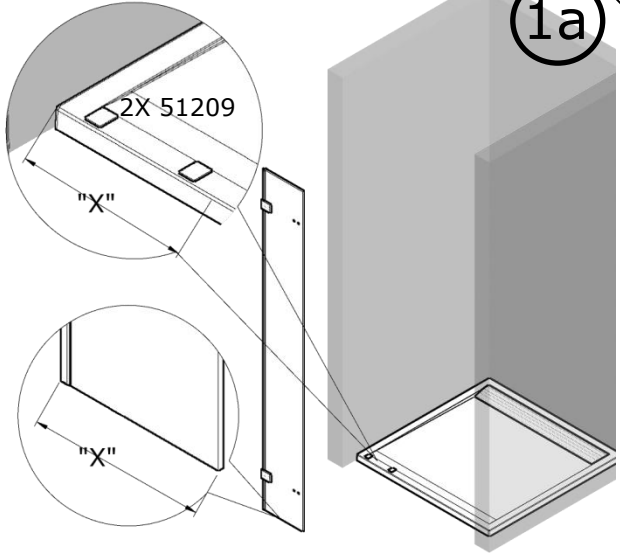

1b

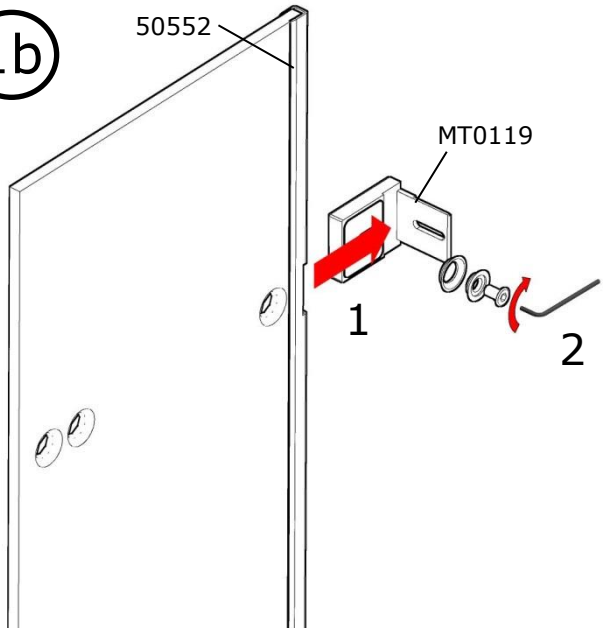

1c

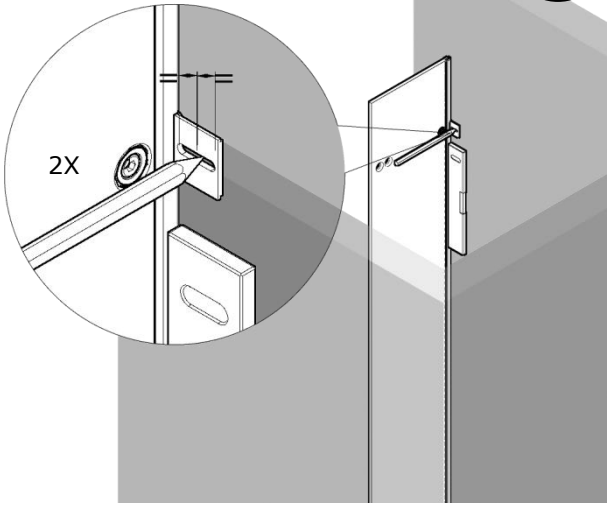

1d

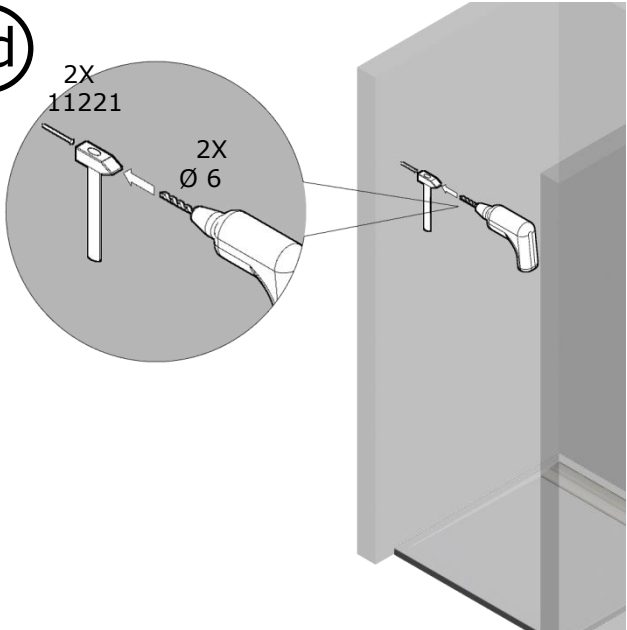

1e

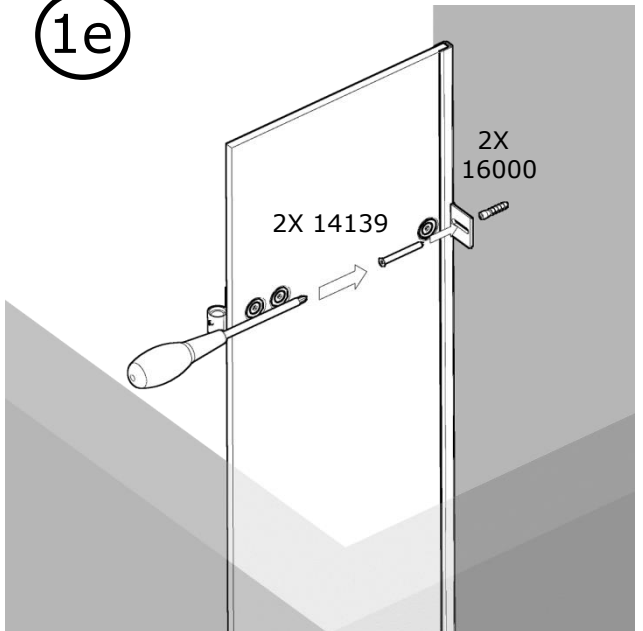

2

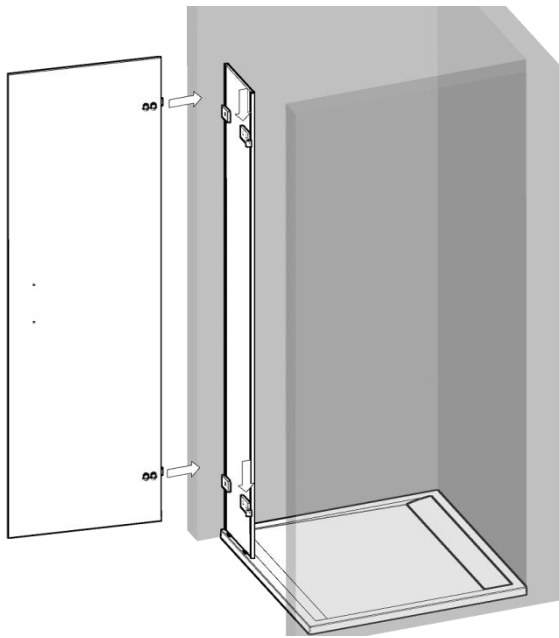

2a

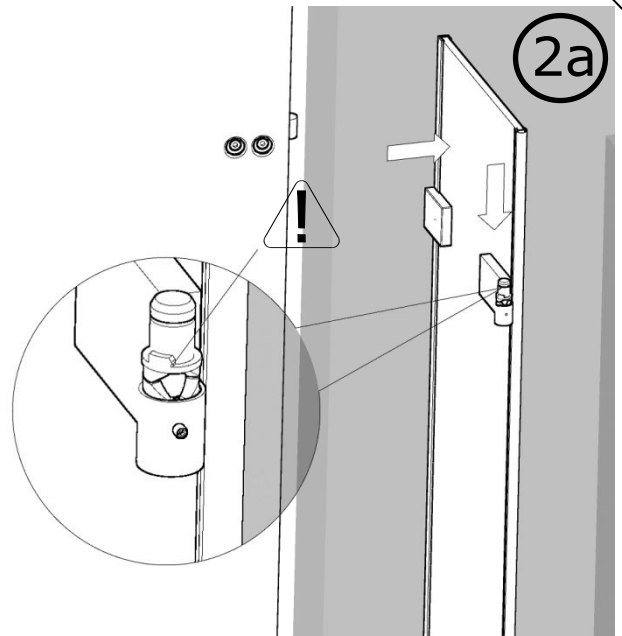

2b

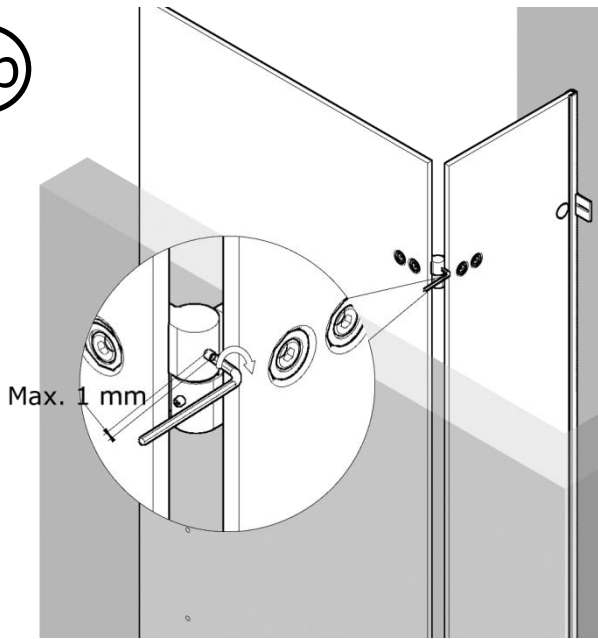

3

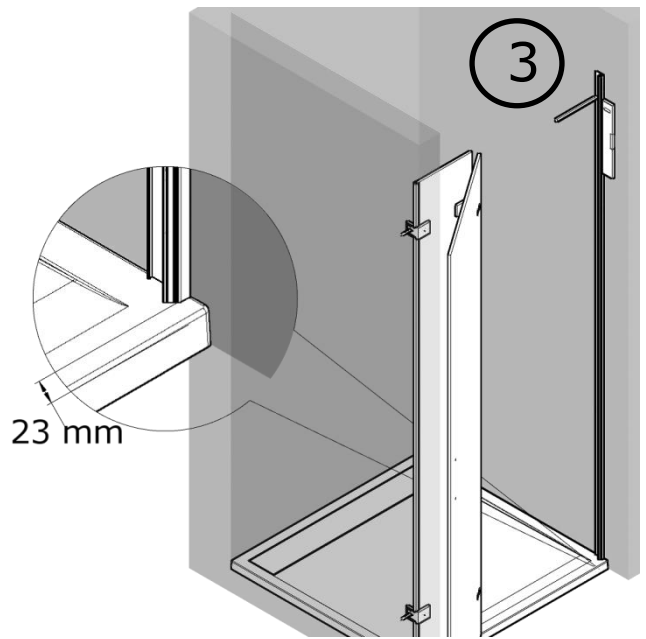

3a

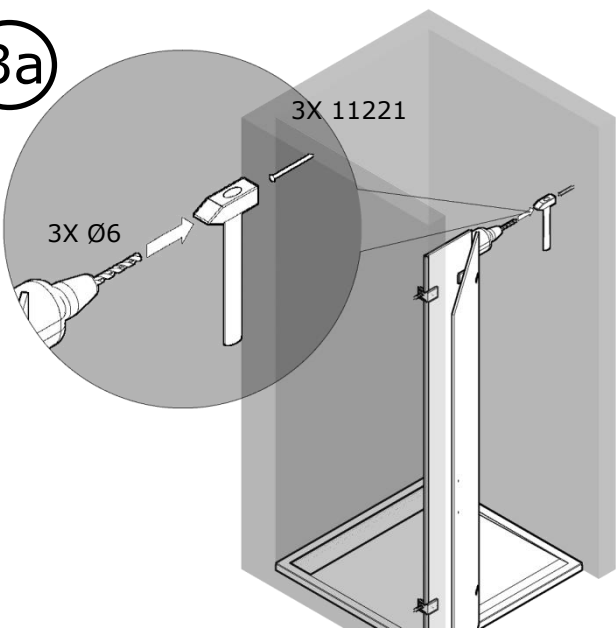

3b

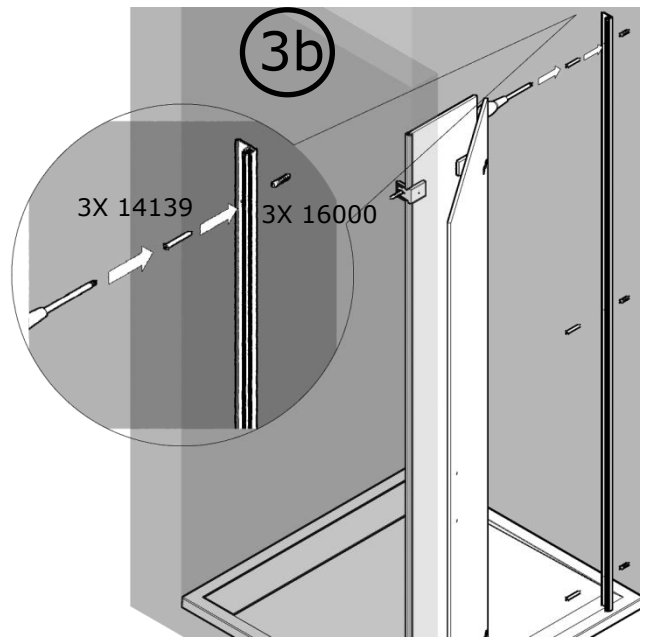

3a

51502
+
50302

51202

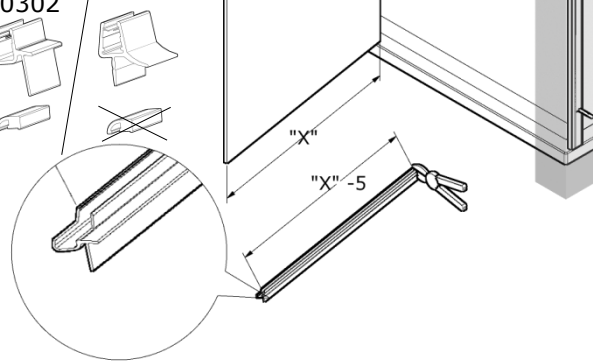

3b

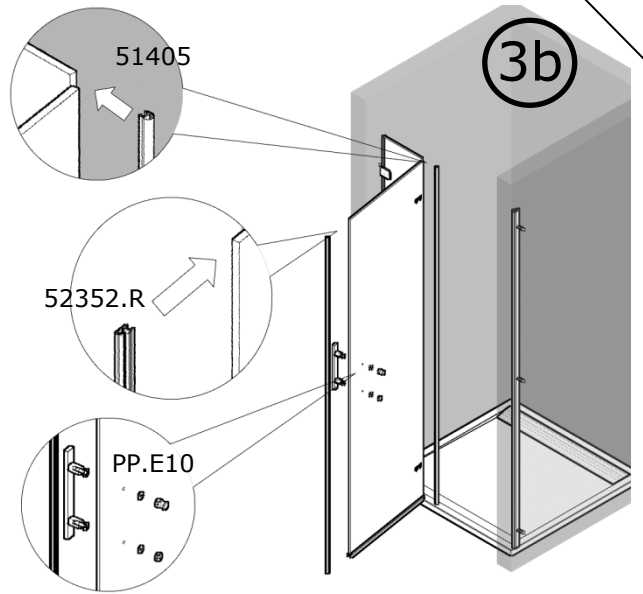

3c

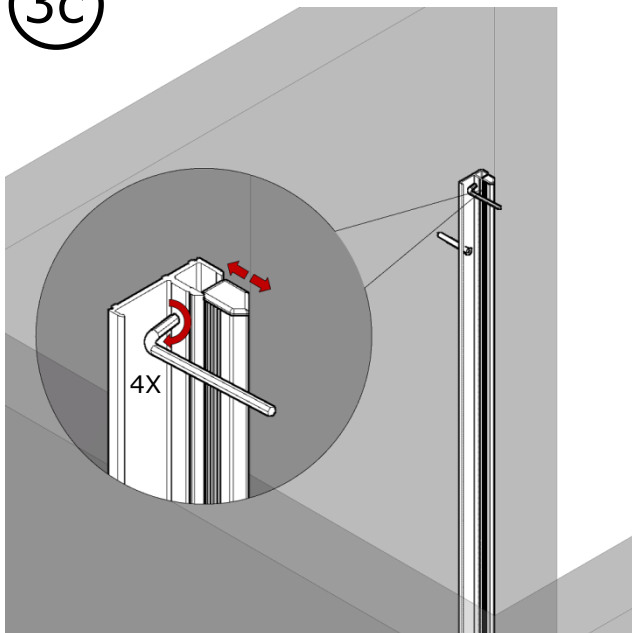

3d

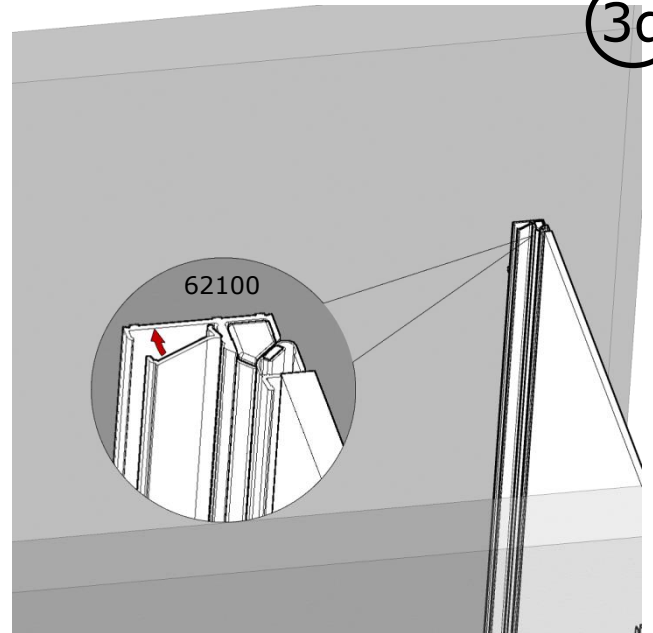

3e

3X 54013

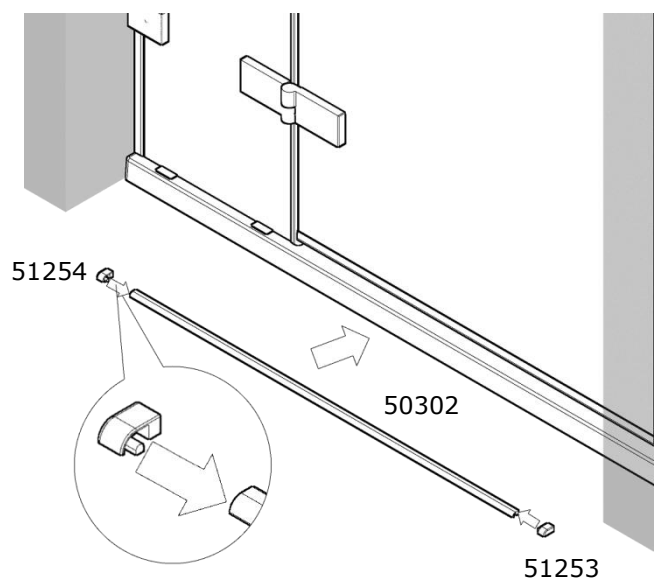
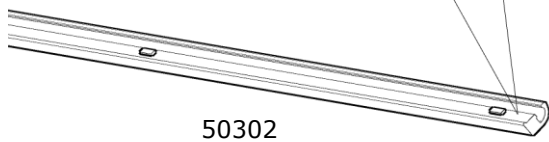
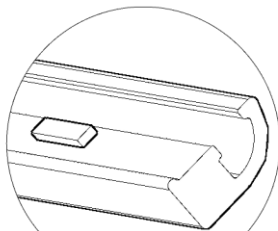

4

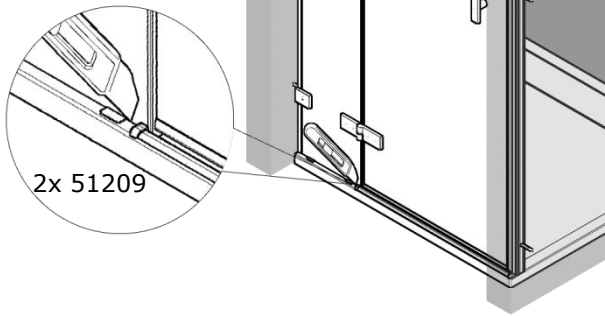

4a

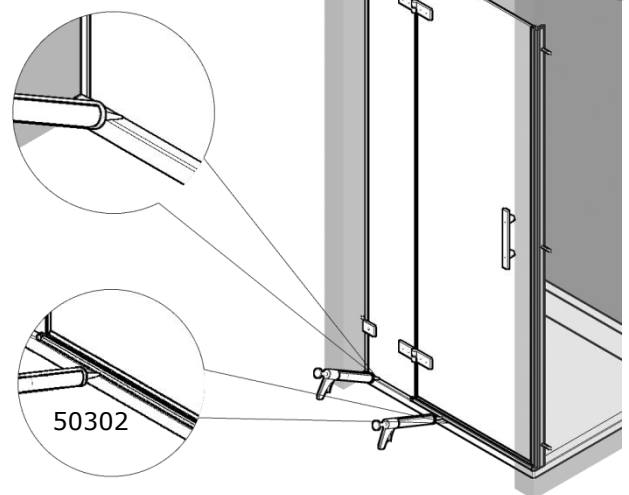

4b

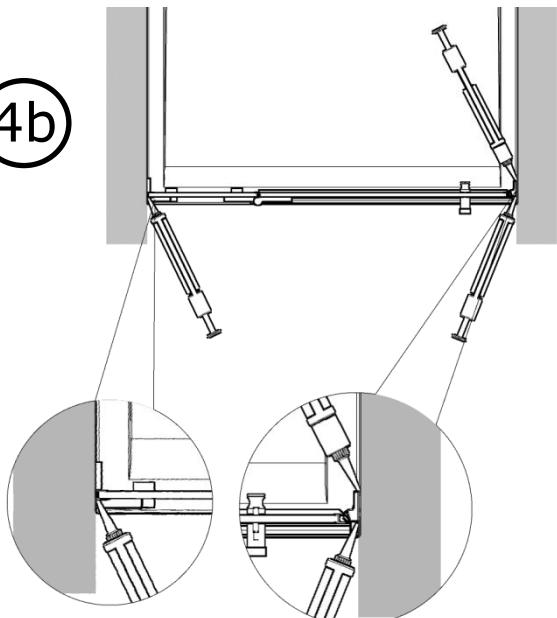

4c

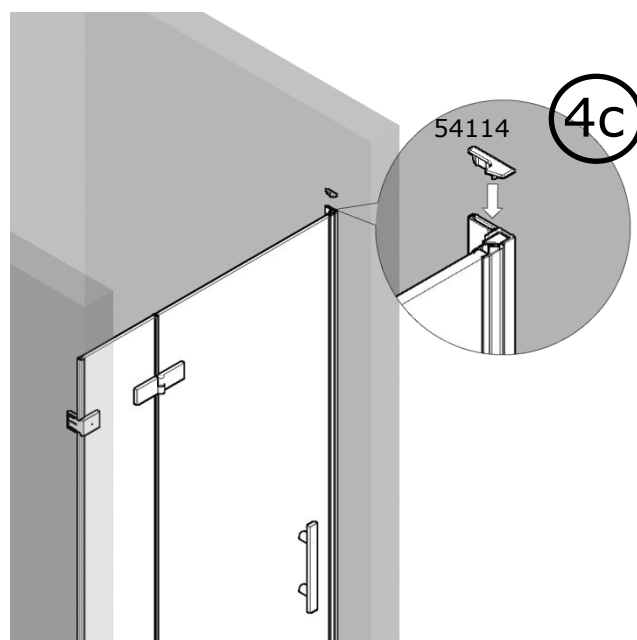

4d

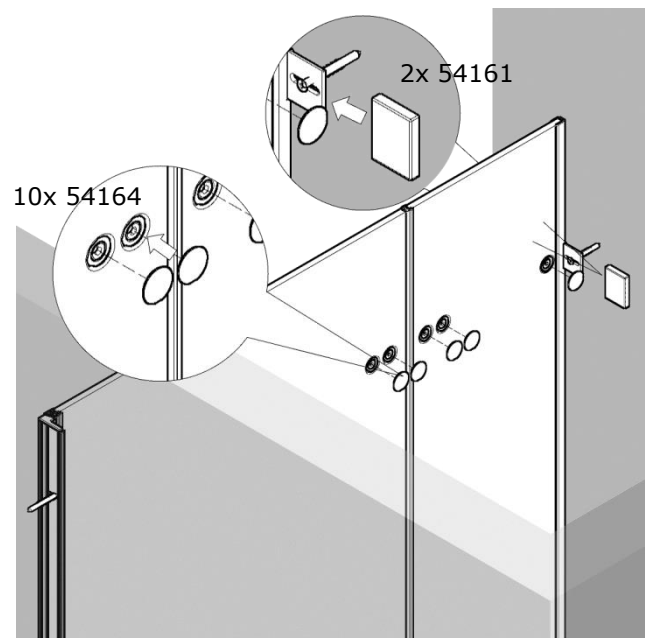

A

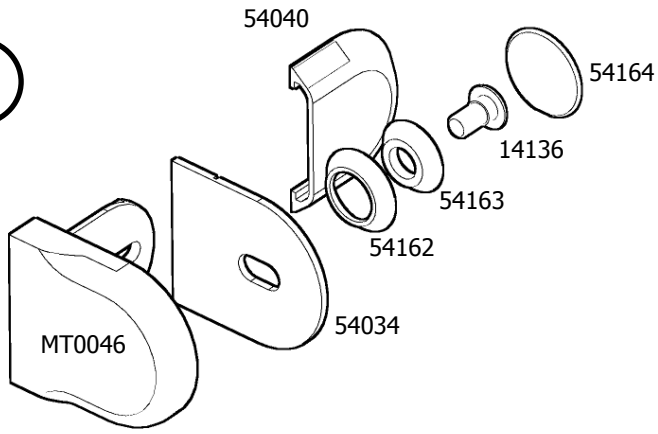

A

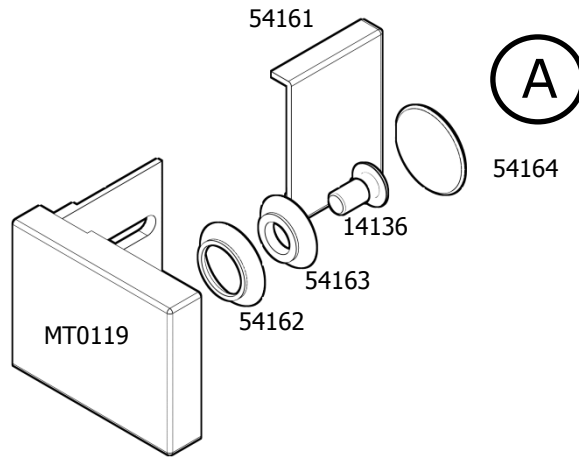

B

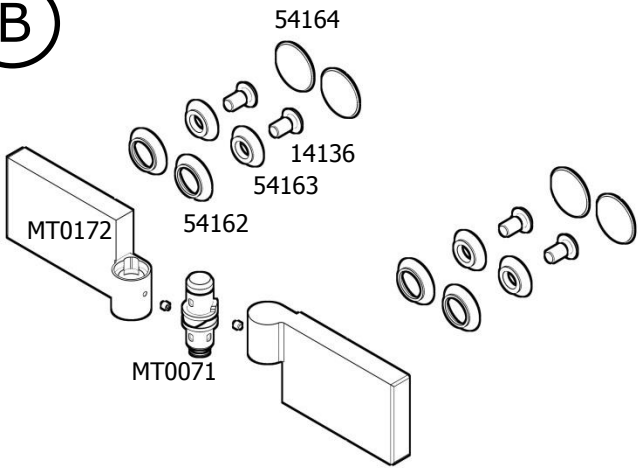

B

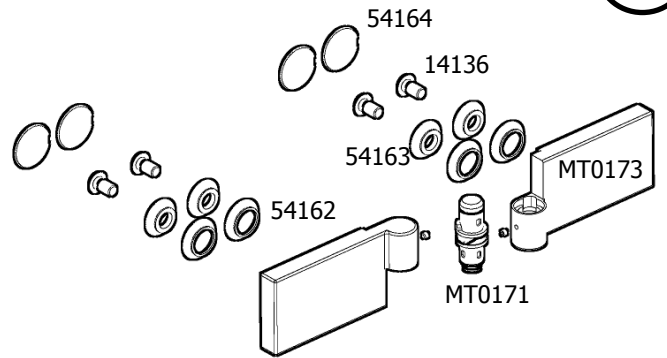

B

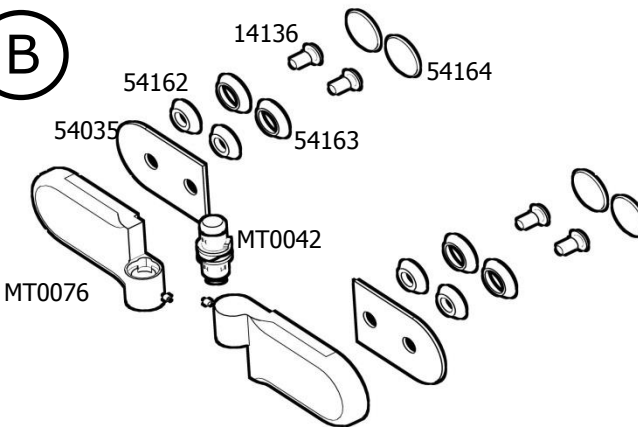

B

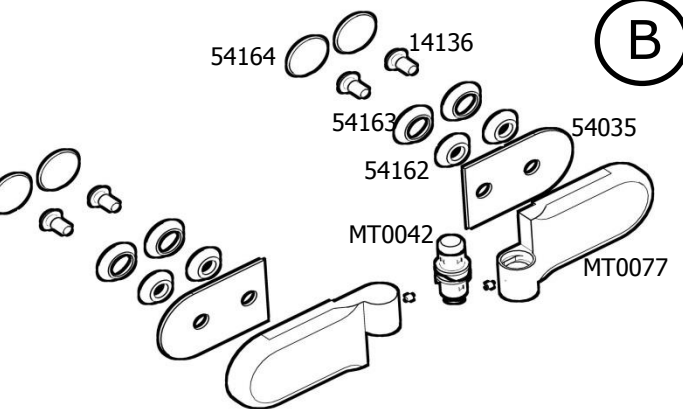

©

PP.E10

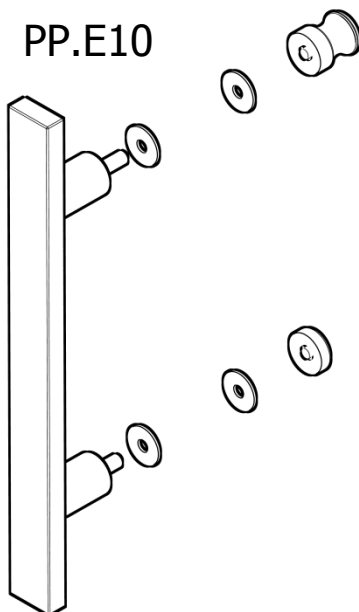

Achtung! Nur Sanitär-Silikon - bakterizid und fungizid eingestellt verwenden.

Caution! Use only bactericidal and fungicide sanitary silicone.

Attention! Utiliser que du silicone sanitaire bactéricide et fungicide.

Pozor! Používejte pouze baktericidní a fungicidní sanitární silikon.

Uwaga! Stosować tylko silikon sanitarny - bakterio i grzybobójczy.

Pozor! Užívajte pouze baktericidný a fungicidný sanitární silikón.

Figyelem! Csak szaniter sziloplaszt - baktérium és gombamentes - használatra megengedett.

Cuidado! Utilizar solamente silicona sanitaria bactericida y fungicida.

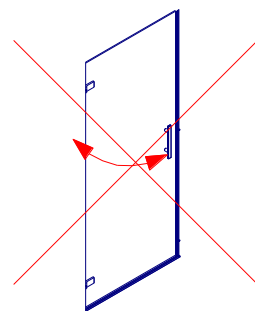
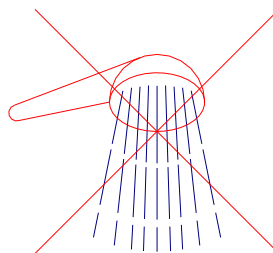

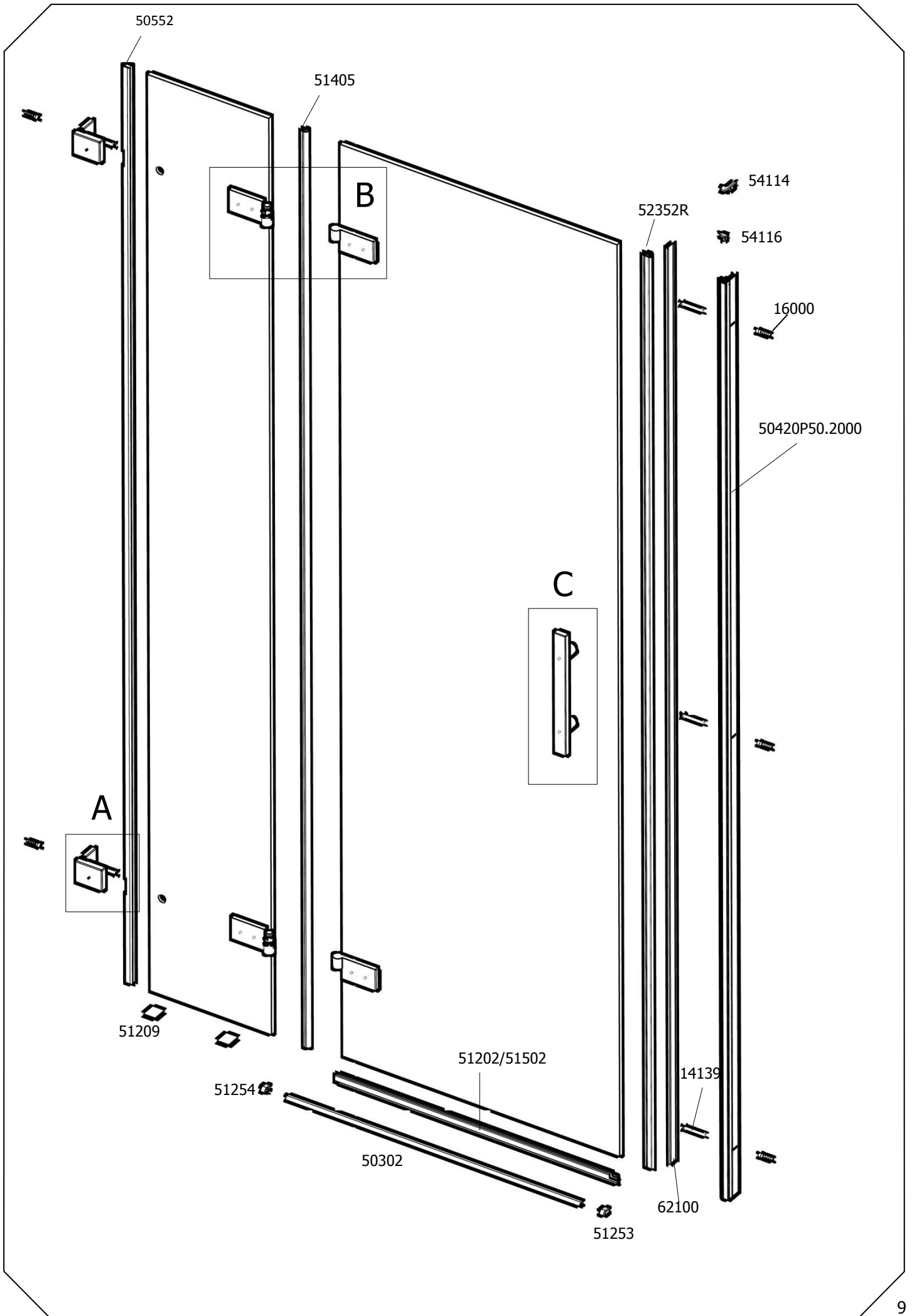



Falls Sie Reklamationen haben, oder Sie unzufrieden mit Ihrem SANSWISS Produkt sind, beschreiben Sie bitte unten auf diesem Blatt den Produktfehler und übergeben Sie dieses Dokument Ihrem Verkäufer, oder direkt der Firma SANSWISS. Diese Information hilft uns, die Qualität von unseren Produkten weiter zu verbessern.



In case of a complaint or Your dissatisfaction with the SANSWISS product, please describe the defect below and pass this document to Your vendor, or directly to the SANSWISS company. This information will help us in the next increase of the quality of our products.



En cas de réclamations lors de la livraison ou l'installation de votre paroi de douche SANSWISS, veuillez, s'il vous plaît, noter vos remarques au bas de la feuille et transmettre les informations à votre revendeur. Elles nous permettrons d'améliorer notre qualité et par la même notre service.



V případě reklamace, či Vaší nespokojenosti s výrobkem SANSWISS popište prosím ve spodní části tohoto listu závadu a dokument prosím odevzdejte Vašemu prodejci nebo přímo firmě SANSWISS. Tato informace nám pomůže v dalším zvýšení kvality našich výrobků.



Reklamacje , oraz inne niezgoności związane z produktem SANSWISS prosimy przekazywać sprzedawcy na załączonym druku.



V prípade reklamácie, alebo Vašej nespokojnosti s výrobkom SANSWISS, popište prosím v spodnej časti tohto listu závalu a dokument prosím odovzdajte Vašemu prodejci, alebo priamo firme SANSWISS. Táto informácia nám pomôže v ďalšom zvýšení kvality našich výrobkov.



Abban az esetben ha reklamációja vagy panasza van az Ön által vásárolt SANSWISS termékkel, úgy azt írja meg a lap alján található helyre és adja át a kereskedőjének, vagy küldje el közvetlenül a SANSWISS cégnek! Ez az információ segít nekünk termékeink minőségének javításában.



En caso de reclamaciones ó si no está satisfecho con su producto SANSWISS, por favor describan en la parte inferior de esta hoja el fallo del producto y entreguen este documento a su vendedor ó directamente a la empresa SANSWISS. Esta información nos ayuda a seguir mejorando la calidad de nuestros productos.



În cazul în care aveți reclamații sau nemulțumiri legate de produsele SANSWISS, vă rugăm să descrieți defectiunea și să transmiteți acest document vânzătorului sau direct firmei SANSWISS. Această informație ne ajută să îmbunătățim în continuare calitatea produselor noastre.

.....
.....
.....
.....