

TOPB3

Ⓛ	MONTAGEANLEITUNG :	FALTWAND 3 TLG
Ⓜ	INSTALLATION INSTRUCTIONS :	BATH SCREEN 3 PANELS
Ⓧ	NOTICE DE MONTAGE :	PARE-BAIN REPLIABLE 3 VLT
Ⓝ	NÁVOD K MONTÁŽI :	SKLADACI ZASTENA TRIDILNA
Ⓟ	INSTRUKCJA MONTAŻU :	PARAWAN 3-CZESCOWY
Ⓢ	NÁVOD NA MONTÁŽ :	SKLADACIA ZASTENA TROJDIELNA
Ⓜ	SZERELÉSI ÚTMUTATÓ :	HÁROMRESZES KADPARAVAN
ⓔ	INSTRUCCIONES DE MONTAJE :	HOJAS PLEGABLES 3 PIEZAS
Ⓡ	INSTRUCTIUNI DE MONTAJ :	PARAVAN PLIABIL 3 PIESE

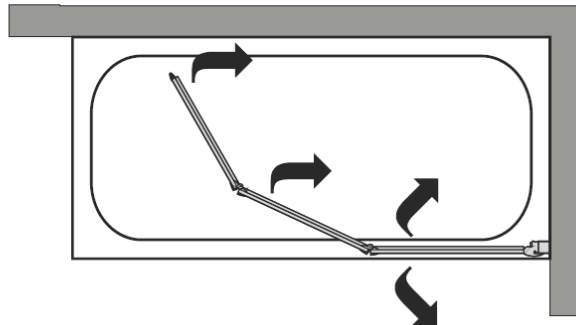
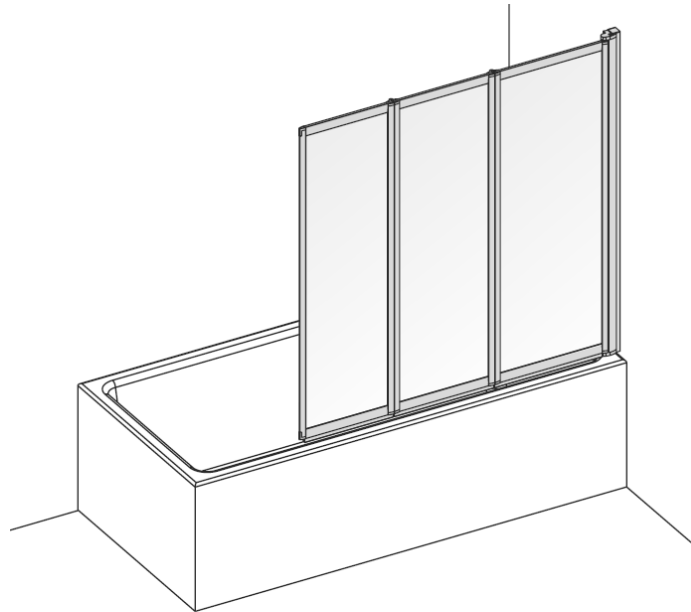

BENÖTIGTES WERKZEUG :

NECESSARY TOOLS :

OUTIL NÉCESSAIRE :

NÁŘADÍ POTŘEBNÉ PRO MONTÁŽ :

SCULE NECESARE :

POTRZEBNE NARZĘDZIA :

POTREBNÉ NÁRADIE:

SZÜKSÉGES SZERSZÁMOK :

HERRAMIENTAS NECESARIAS :

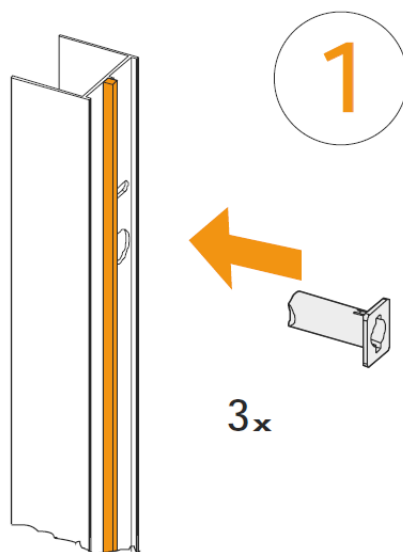
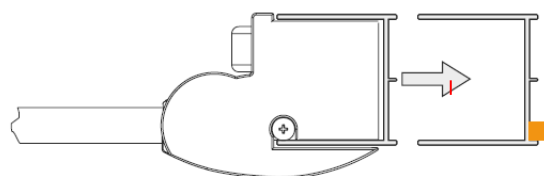
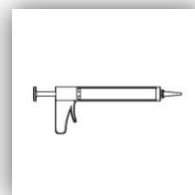
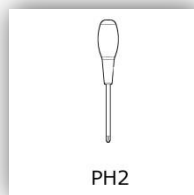
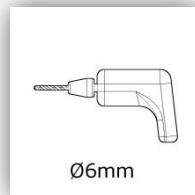
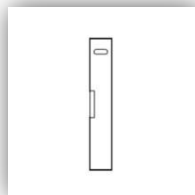
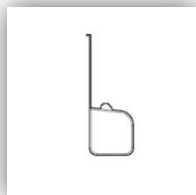
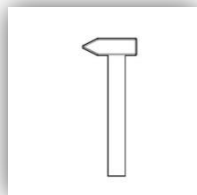

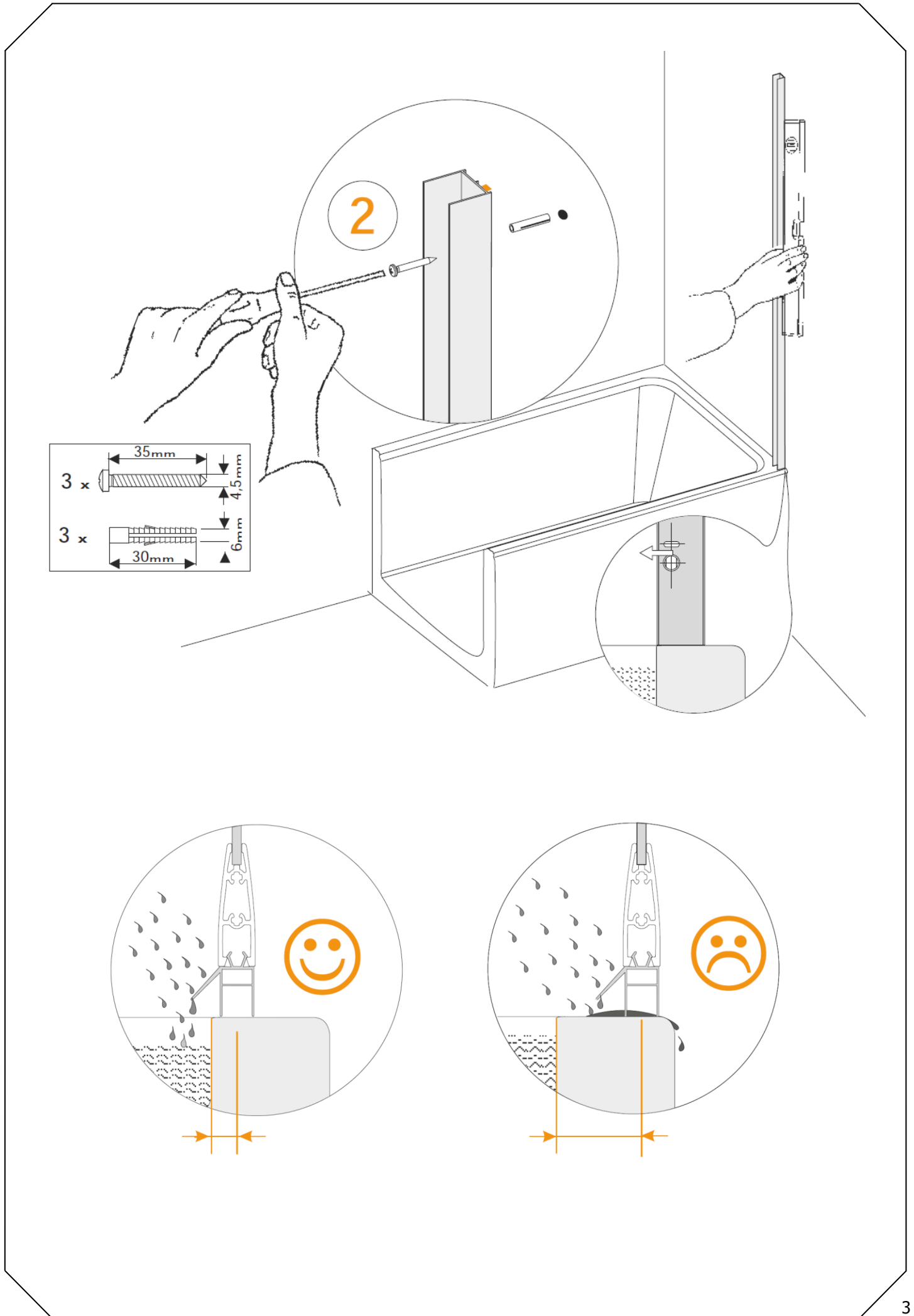

3

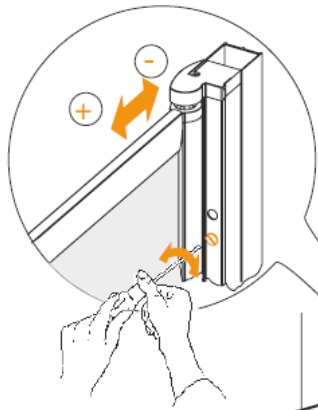

4

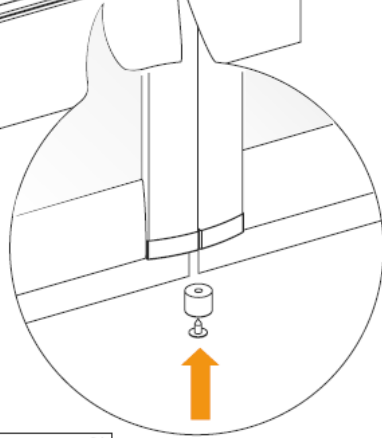
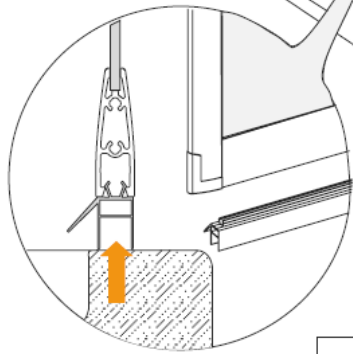
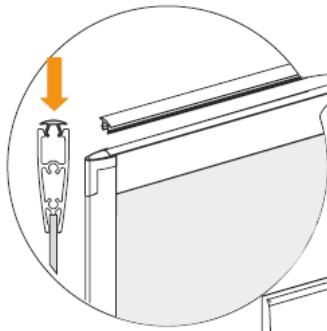

5

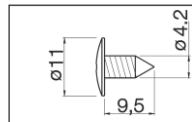

6

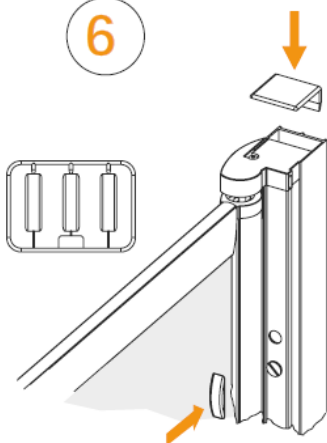

7

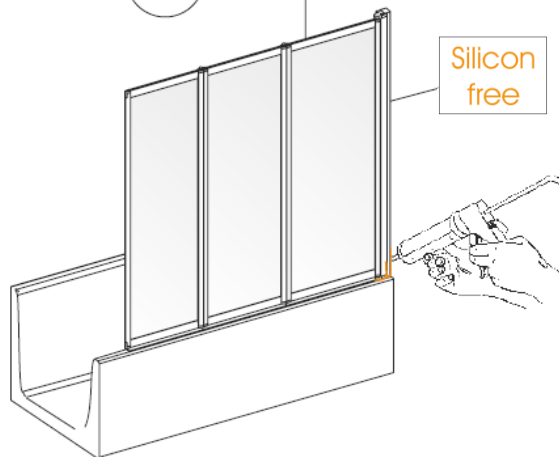

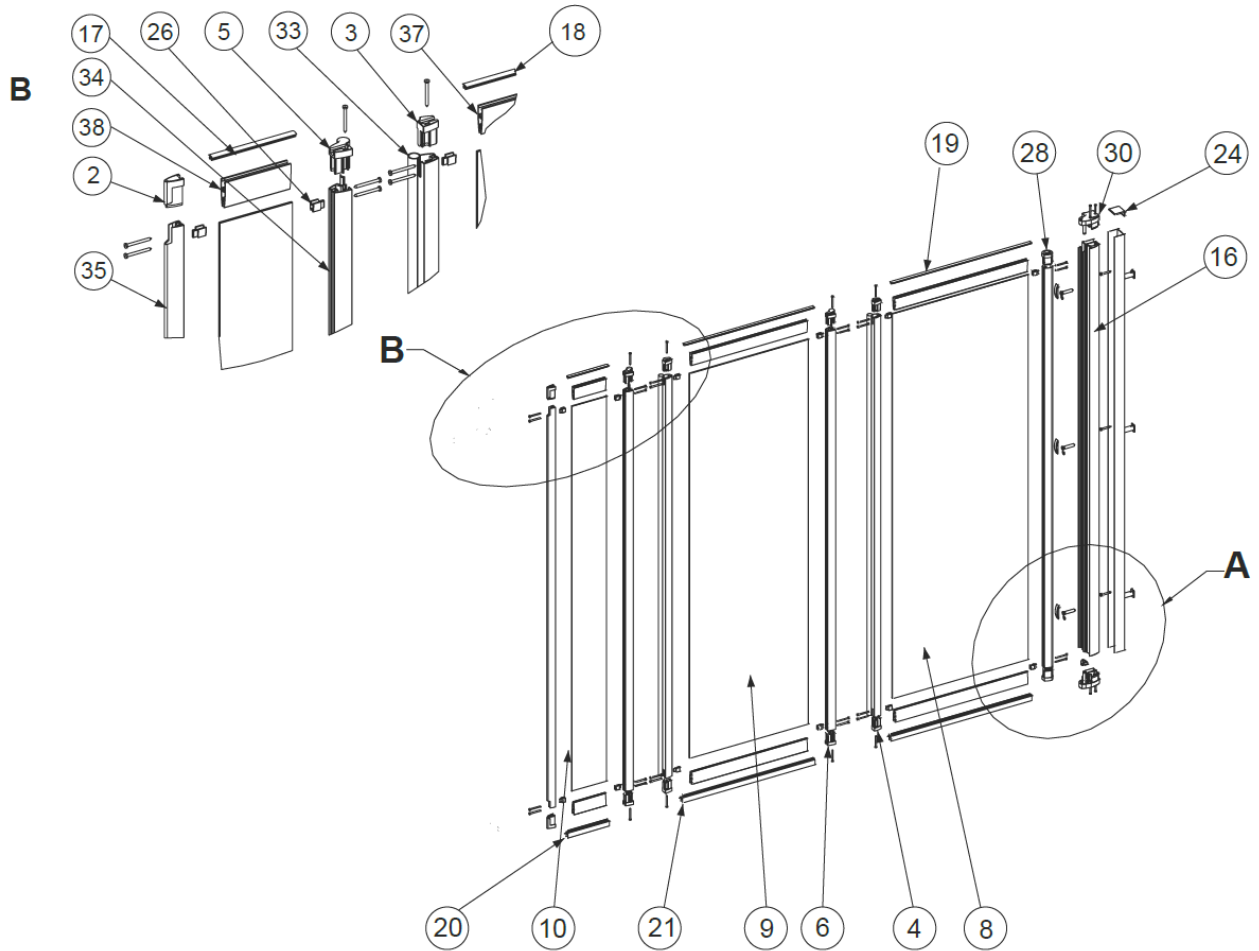

Pos	Article code	quant.	Material
1	621KS**F	3	ABS
2	623KS**F	2	PA6
3	623KS**F	2	PA6
4	623KS**F	2	PA6
5	623KS**F	2	PA6
6	623KS**F	2	PA6
7	0607AL**G	1	AlMgSi05
8	***	1	Glas
9	***	1	Glas
10	***	1	Glas
11	001BF00F	2	INOX
12	009BF00F	36	INOX
13	010BF00F	3	Messing
14	011BF00F	3	INOX
15	016BZ00F	2	INOX
16	060GM07F	4	PVC
17	100GM08F	1	PVC
18	100GM08F	1	PVC
19	100GM08F	1	PVC
20	110GM08F	1	PVC WEICH/HART
21	110GM08F	1	PVC WEICH/HART
22	110GM08F	1	PVC WEICH/HART
23	430KS18F	3	POM
24	445KS**F	1	ABS
25	602AL**G	1	AlMgSi05
26	620KS18F	12	PA6
27	622KS18F	1	DELRIN
28	624KS**FL	1	PA6
29	624KS**FR	1	PA6
30	625KS**FL	1	PA6
31	625KS**FR	1	PA6
32	790AL**G	1	AlMgSi05
33	795AL**G	2	AlMgSi05
34	800AL**G	2	AlMgSi05
35	805AL**G	1	AlMgSi05
36	810AL**G	2	AlMgSi05
37	811AL**G	2	AlMgSi05
38	812AL**G	2	AlMgSi05

** 05 brillant
20 silber
30 weiß/weiß

* SC Satiniert
OG Cincilla
GL Transparent
AC Acrylic

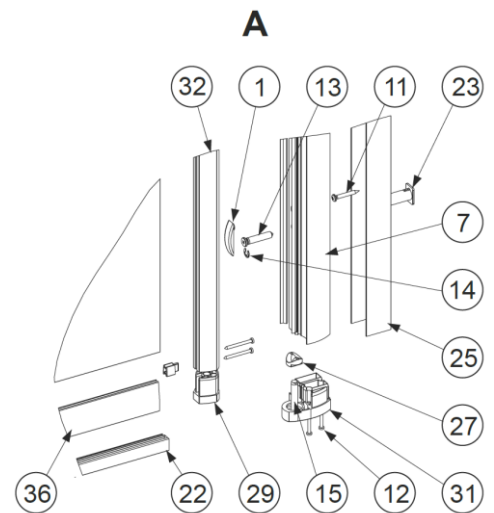

QUALITY CONTROL



Falls Sie Reklamationen haben, oder Sie unzufrieden mit Ihrem SANSWISS Produkt sind, beschreiben Sie bitte unten auf diesem Blatt den Produktfehler und übergeben Sie dieses Dokument Ihrem Verkäufer, oder direkt der Firma SANSWISS. Diese Information hilft uns, die Qualität von unseren Produkten weiter zu verbessern.



In case of a complaint or Your dissatisfaction with the SANSWISS product, please describe the defect below and pass this document to Your vendor, or directly to the SANSWISS company. This information will help us in the next increase of the quality of our products.



En cas de réclamations lors de la livraison ou l'installation de votre paroi de douche SANSWISS, veuillez, s'il vous plaît, noter vos remarques au bas de la feuille et transmettre les informations à votre revendeur. Elles nous permettent d'améliorer notre qualité et par la même notre service.



V případě reklamace, či Vaší nespokojenosti s výrobkem SANSWISS popište prosím ve spodní části tohoto listu závadu a dokument prosím odevzdejte Vašemu prodejci nebo přímo firmě SANSWISS. Tato informace nám pomůže v dalším zvýšení kvality našich výrobků.



Reklamacje , oraz inne niezgoności związane z produktem SANSWISS prosimy przekazywać sprzedawcy na załączonym druku.



V prípade reklamácie, alebo Vašej nespokojnosti s výrobkom SANSWISS, popište prosím v spodnej časti tohto listu závadu a dokument prosím odovzdajte Vašemu prodejci, alebo priamo firme SANSWISS. Táto informácia nám pomôže v ďalšom zvýšení kvality našich výrobkov.



Abban az esetben ha reklamációja vagy panasza van az Ön által vásárolt SANSWISS termékkel, úgy azt írja meg a lap alján található helyre és adja át a kereskedőjének, vagy küldje el közvetlenül a SANSWISS cégnek! Ez az információ segít nekünk termékeink minőségének javításában.



En caso de reclamaciones ó si no está satisfecho con su producto SANSWISS, por favor describan en la parte inferior de esta hoja el fallo del producto y entreguen este documento a su vendedor ó directamente a la empresa SANSWISS. Esta información nos ayuda a seguir mejorando la calidad de nuestros productos.



În cazul în care aveți reclamații sau nemulțumiri legate de produsele SANSWISS, vă rugăm să descrieți defectiunea și să transmiteți acest document vânzătorului sau direct firmei SANSWISS. Această informație ne ajută să îmbunătățim în continuare calitatea produselor noastre.

.....
.....
.....
.....

.....