

## QUALITY CONTROL:

- D** Dieses Produkt wurde unter sorgfältiger Beachtung der Qualitäts-Richtlinien gefertigt und vor dem Verpacken einer eingehenden Prüfung unterzogen. Sollten Sie dennoch einen Produktmangel oder eine Beschädigung feststellen, so setzen Sie sich bitte direkt mit der Firma in Verbindung, bei der Sie dieses Produkt gekauft haben.
- GB** This product was made with careful attention to quality guidelines and was subjected to a thorough examination before packaging. However, if you find a product defect or damage so please get in touch directly with the company in which you have bought this product.
- F** Ce produit est fabriqué avec une attention particulière selon des normes de qualité et est soumis à un contrôle approfondi avant l'emballage. Toutefois, si le produit présente un défaut ou un dommage, veuillez prendre contact avec l'entreprise qui vous a vendu ce produit.
- CZ** Tento produkt byl vyroben s odbornou péčí podle příslušných kvalitativních směrnic a před zabalením byl důkladně zkontrolován. Pokud u něho přesto zjistíte závadu nebo poškození, kontaktujte prosím firmu, u které jste výrobek zakoupili.
- PL** Produkt ten został wyprodukowany z uwzględnieniem rygorystycznych norm jakościowych, a następnie podany drobiazgowej kontroli przed zapakowaniem. Jeżeli po rozpakowaniu (przed rozpoczęciem montażu!) stwierdzicie Państwo wady lub uszkodzenia to prosimy o natychmiastowe zgłoszenie tego faktu sprzedawcy.
- SK** Tento produkt bol vyrobený s odbornou starostlivosťou podľa príslušných kvalitatívnych smerníc a pred zabalením bol dôkladne skontrolovaný. Ak u neho aj napriek tomu zistíte závadu alebo poškodenie, kontaktujte prosím firmu, u ktorej ste výrobok zakúpili.
- RU** Это изделие было изготовлено с особым вниманием в соответствии с высокими стандартами качества и было тщательно проверено перед упаковкой. В то же время, если вы обнаружите дефект или повреждение, обратитесь в компанию, у которой вы купили это изделие.
- E** Este producto ha sido fabricado cumpliendo estrictamente las normativas de calidad y ha sido sometido a un control exhaustivo antes de embalarlo. En caso de que a pesar de ello, Usted note algún desperfecto del producto, rogamos se ponga en contacto directamente con la empresa donde haya comprado el producto.
- RO** Acest produs a fost fabricat respectând cele mai stricte norme de calitate, iar produsul a fost testat înainte de a fi împachetat. Dacă totuși observați o neregulă sau o defecțiune, vă rugăm să contactați direct firma de la care ați achiziționat produsul.

.....  
.....  
.....  
.....  
.....  
.....



# 19259

<b>D</b>	MONTAGEANLEITUNG:	RUNDDUSCHE MIT ZWEI SCHIEBETÜREN
<b>GB</b>	INSTALLATION INSTRUCTIONS:	ROUND ENCLOSURE WITH 2 SLIDING DOORS
<b>F</b>	NOTICE DE MONTAGE:	PORTE COULISSANTE QUART DE ROND
<b>CZ</b>	NÁVOD K MONTÁŽI:	ČTVRTKRUHOVÁ ZÁSTĚNA SE DVĚMA POSUVNÝMI DVEŘMI
<b>PL</b>	INSTRUKCJA MONTAŻU:	KABINA PÓŁOKRĄGŁA
<b>SK</b>	NÁVOD NA MONTÁŽ:	ŠTVRTKRUHOVÁ ZÁSTĚNA S DVOMA POSUVNÝMI DVERAMI
<b>RU</b>	ИНСТРУКЦИЯ ПО МОНТАЖУ:	ПОЛУКРУГЛАЯ РАЗДВИЖНАЯ ДВЕРЬ
<b>E</b>	INSTRUCCIONES DE MONTAJE:	SEMICIRCULAR 2 HOJAS CORREDERAS
<b>RO</b>	INSTRUCȚIUNI DE MONTAJ:	SFERT DE CERC – 2 UȘI CULISANTE

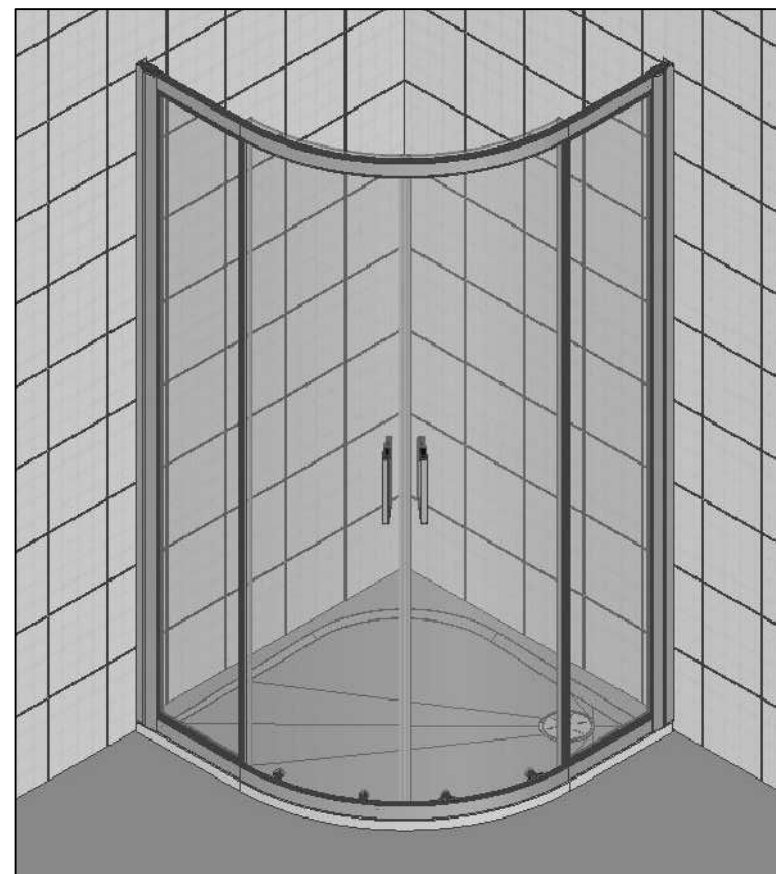

Benötigtes Werkzeug:  
 Necessary tools:  
 Outil Nécessaire:  
 Nářadí potřebné pro montáž:

Potrzebne narzędzia:  
 Potrebne náradie:  
 необходимые инструменты:  
 Herramientas necesarias:



1x

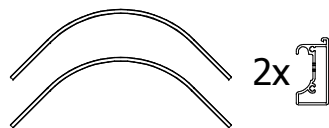
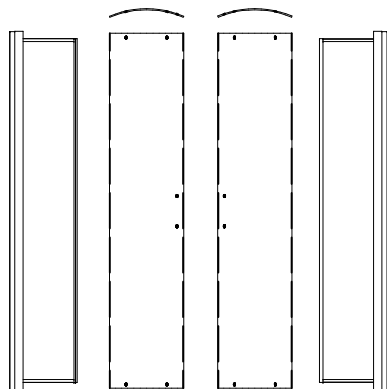
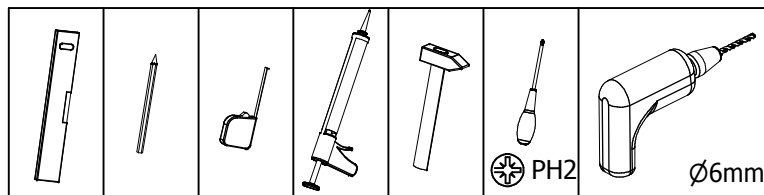

2x





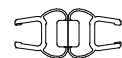









2x82111

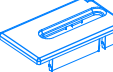

42356 L+R

Zubehör:  
 Equipment:  
 Accessoires:  
 Příslušenství:

Dodatki:  
 Príslušenstvo:  
 Аксессуары:  
 Accesorios:

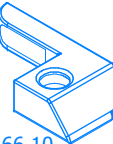
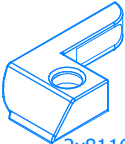
 1x11221	 6x11295	 6x14118 4,2x32mm	 6x16000 Ø6mm	 8x14003 3,5x9,5 mm
 8x14016 3,5x25 mm	 2x14196 3,5x13 mm	 2x81230	 2x81330	 2xMT8010.10
 8x81393	MT8012.10			
 8x81163	 4x81164.10	 2x81166.10	 2x81167.10	

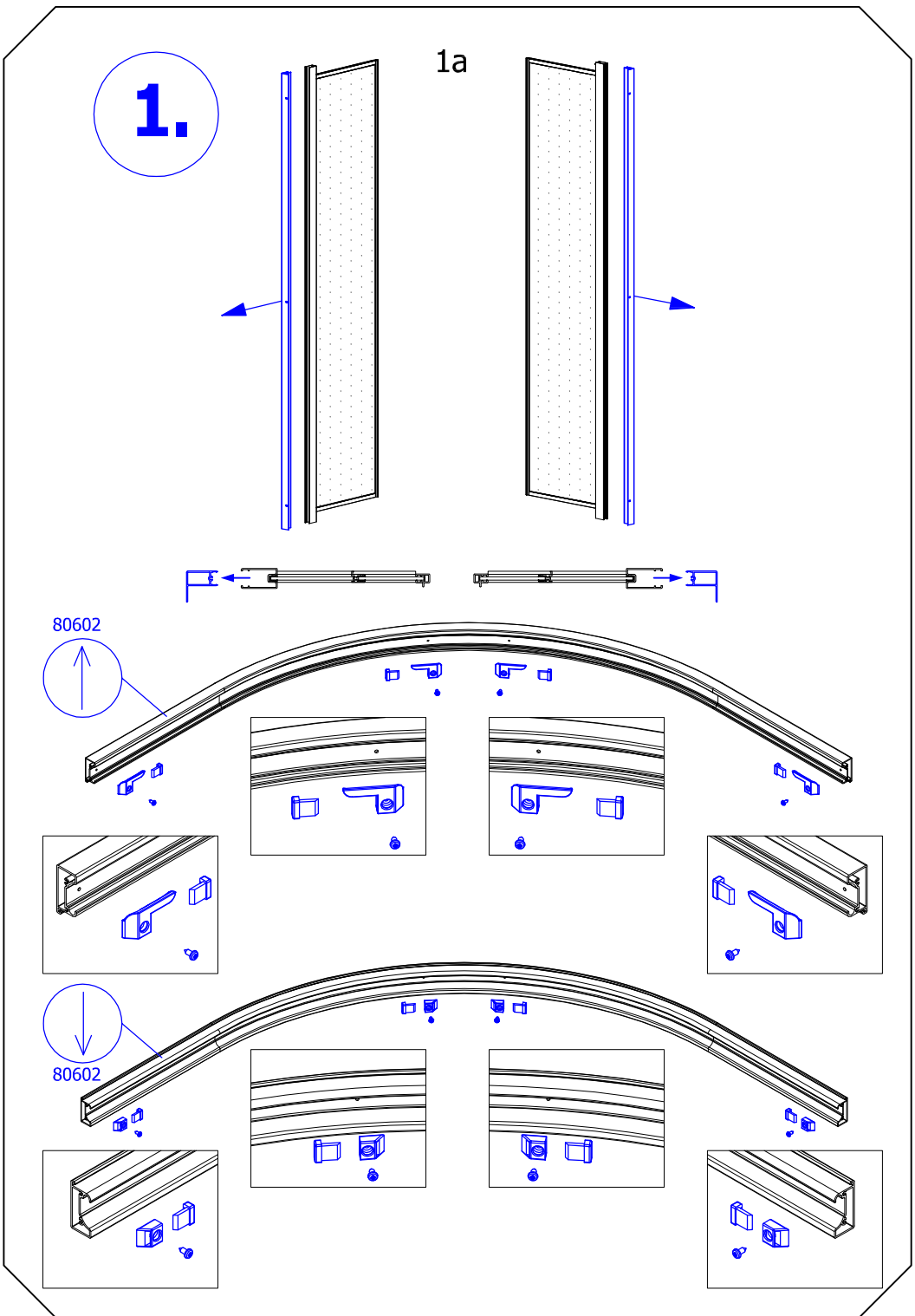
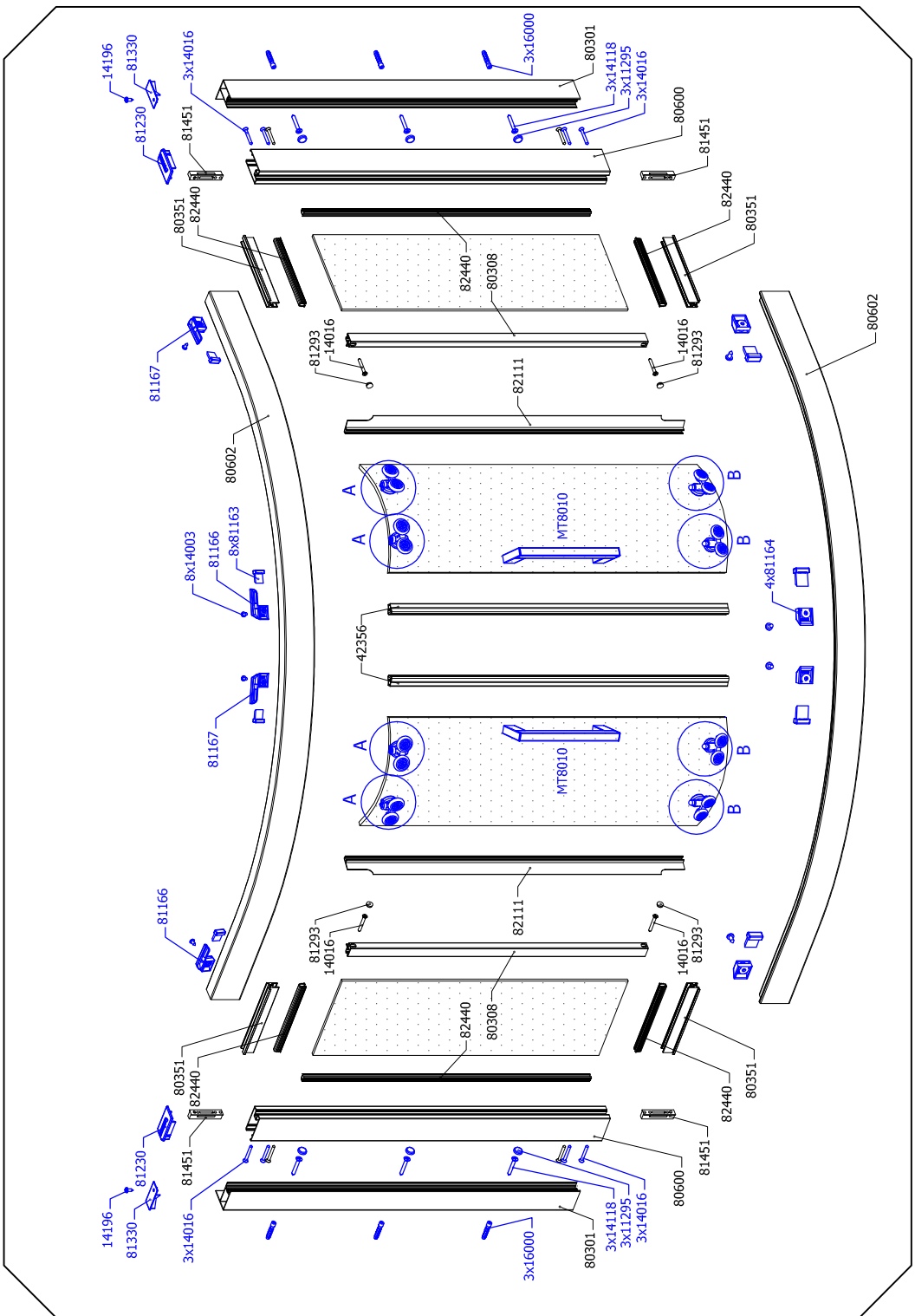

2.

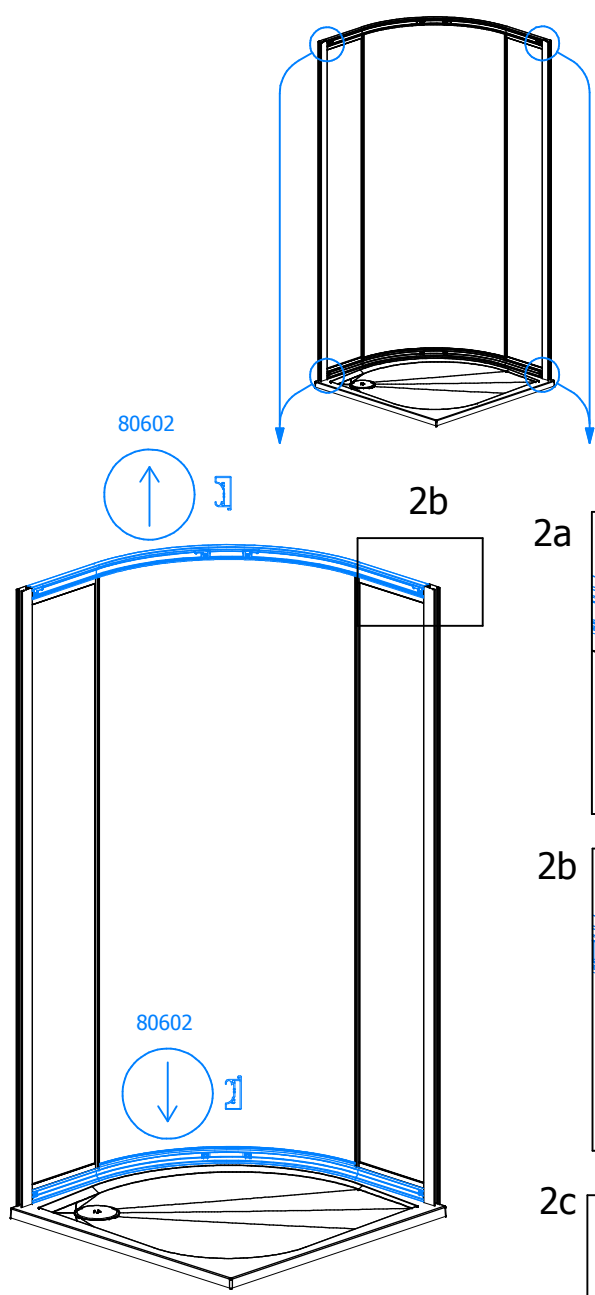

80602



2b

2a

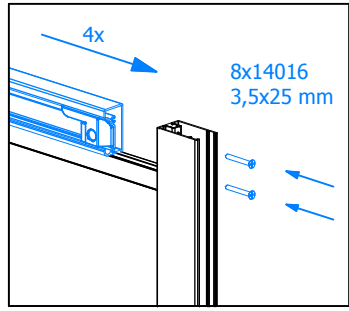

2b

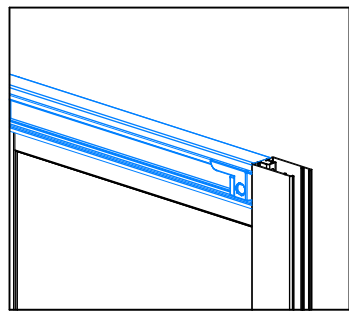

2c

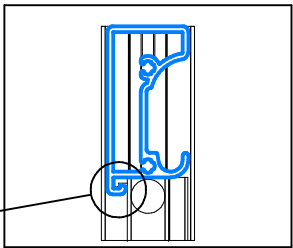

MT8010.10

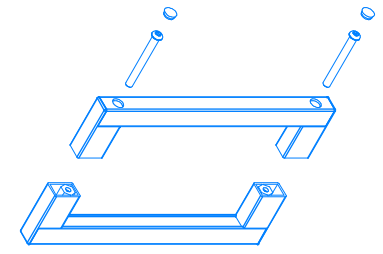

A: MT8004(4x)+81393(4x)

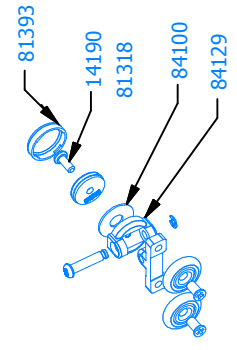

B: MT8002(4x)+81393(4x)

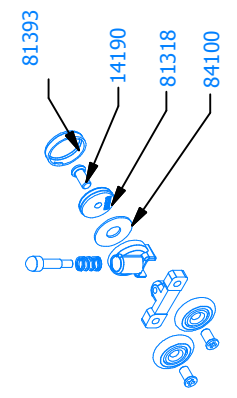

11.

10a

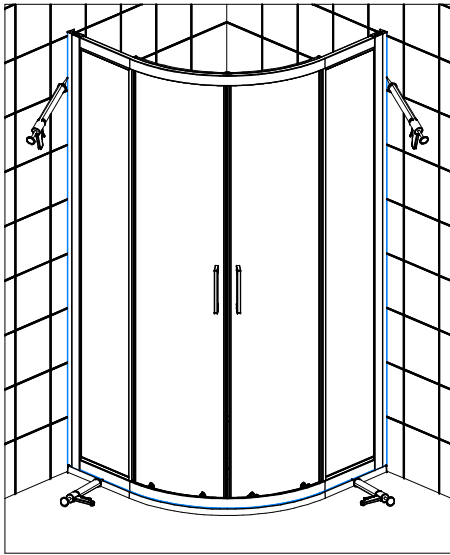

10b

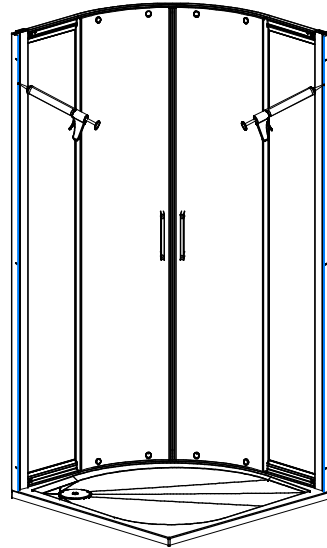

10c

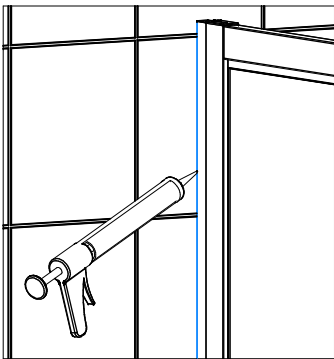

10d

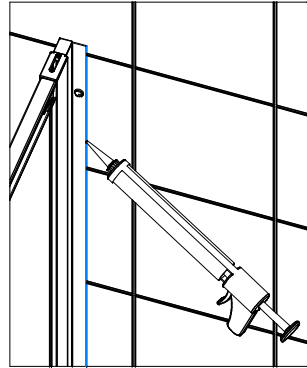

Achtung! Nur Sanitär-Silikon - bakterizid und fungizid eingestellt verwenden.

Caution! Use only bactericidal and fungicide sanitary silicone.

Attention! N'utiliser que du silicone sanitaire bactéricide et fongicide.

Pozor! Používejte pouze baktericidní a fungicidní sanitární silikon.

Uwaga! Stosować tylko silikon sanitarny - bakterio i grzybobójczy.

Pozor! Užívajte pouze baktericidný a fungicidný sanitárny silikón.

Внимание! Применяйте только антибактериальные силиконовые герметики с фунгицидом

Cuidado! Utilizar solamente silicona sanitaria bactericida y fungicida.

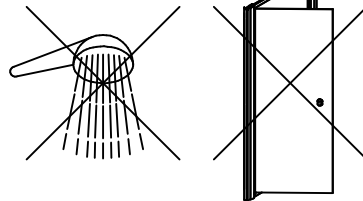

10.

(D) Verstellbereich für Montage auf Duschwanne oder bodenebenen.

(GB) Presetting range for assablage on the shower tray or on the pavage.

(F) Plage de réglage pour une pose sur receveur ou à l'italienne.

(CZ) Přestavné míry pro montáž na vaničku nebo na dlažbu.

(PL) Zakres regulacji do montażu na brodziku lub bezpośrednio na posadzce.

(SK) Prestavná šírka pre montáž na vaničku alebo podlahu.

(RU) Регулировка ширины для установки на душевой поддон или на пол.

(E) Zona de ajuste en platos de ducha o a ras de suelo.

3a

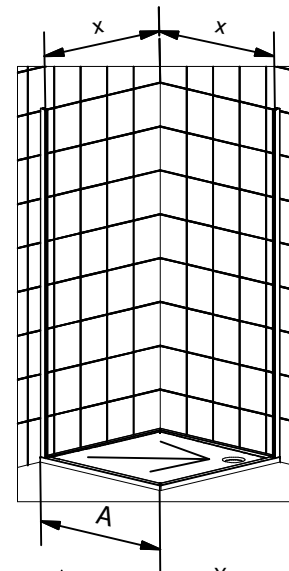

3b

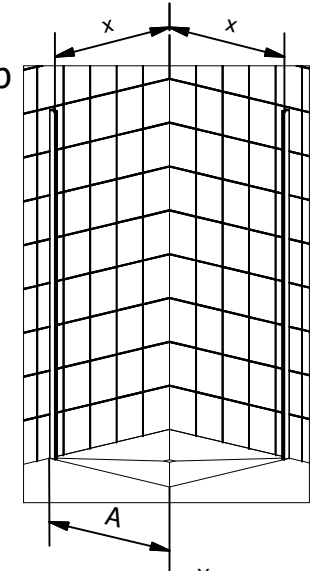

3c

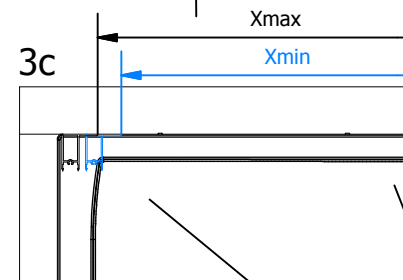

3d

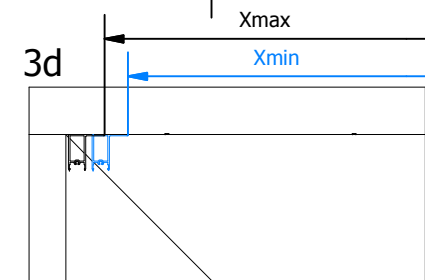

A	X min	X max
800	734	759
900	834	859
1000	934	959

3.

4a

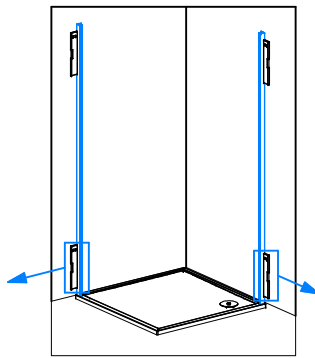
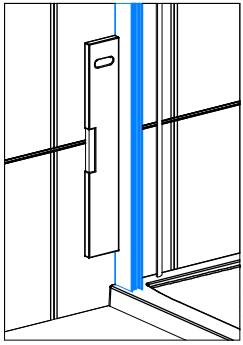

4b

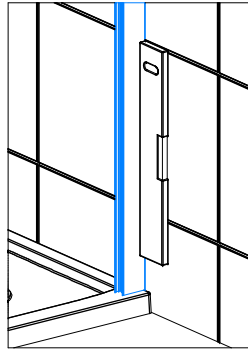

L/R

4c

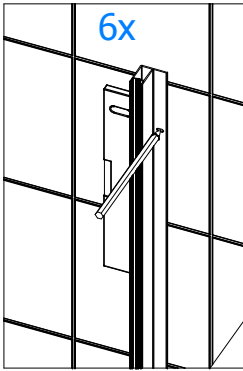

6x

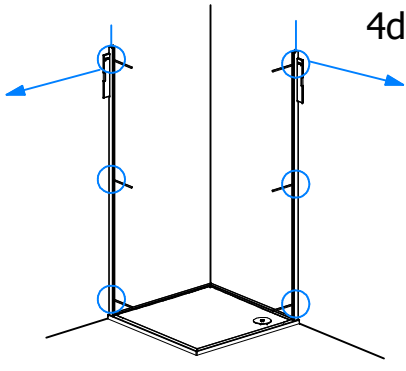

4d

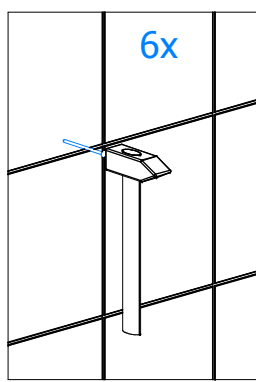

6x

4e

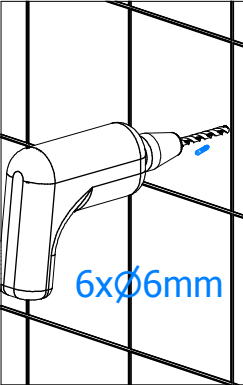

6xØ6mm

4f

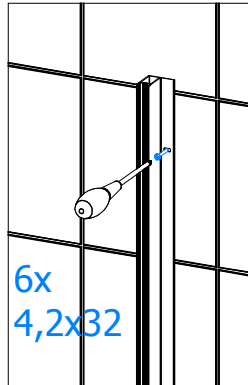

6x  
4,2x32

4g

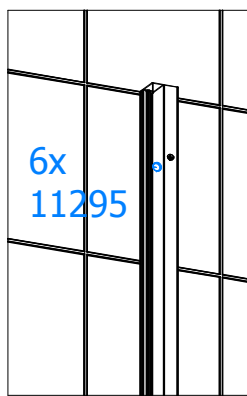

6x  
11295

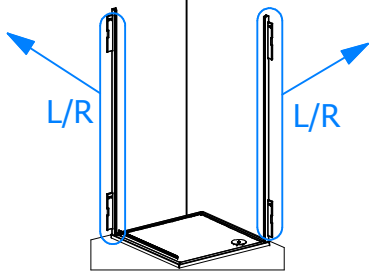

L/R

L/R

4.

9a

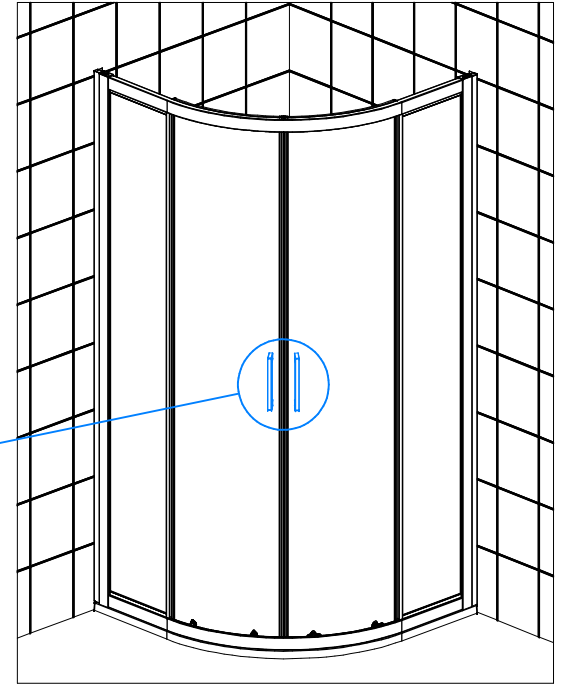

ZUBEHÖR

L/R

MT8010.10

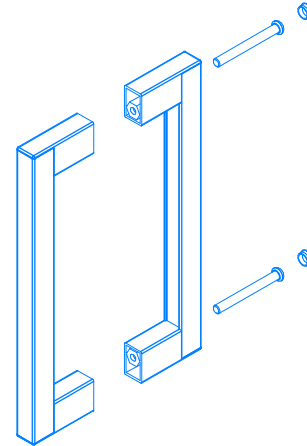

9.

